

# A5s Plus (E)

## Receiving Card



Specifications

## Change History

Document Version	Release Date	Description
V1.0.3	2021-11-16	<ul style="list-style-type: none"> <li>Updated the appearance diagram.</li> <li>Updated the certification related description.</li> </ul>
V1.0.2	2021-08-18	Updated the side-view dimensions diagram.
V1.0.1	2021-07-30	<ul style="list-style-type: none"> <li>Updated the description of features.</li> <li>Added the certification related description.</li> </ul>
V1.0.0	2021-04-01	First release

## Introduction

The A5s Plus (E) is a general small receiving card developed by NovaStar. A single A5s Plus (E) loads up to 512x384 pixels (NovaLCT V5.3.1 or later required). Supporting various functions such as color management, 18bit+, pixel level brightness and chroma calibration, individual gamma adjustment for RGB, and 3D, the A5s Plus (E) can significantly improve the display effect and user experience.

The A5s Plus (E) uses high-density connectors for communication to limit the effects of dust and vibration, resulting in high stability. It supports up to 32 groups of parallel RGB data or 64 groups of serial data (expandable to 128 groups of serial data). Its reserved pins allow for custom functions of users. Thanks to its EMC Class B compliant hardware design, the A5s Plus (E) has improved electromagnetic compatibility and is suitable for various on-site setups.

## Certifications

RoHS, EMC Class B

**If the product does not have the relevant certifications required by the countries or regions where it is to be sold, please contact NovaStar to confirm or address the problem. Otherwise, the customer shall be responsible for the legal risks caused or NovaStar has the right to claim compensation.**

## Features

### Improvements to Display Effect

- Color management  
 Allow users to freely switch the color gamut of the screen between different gamuts in real time to enable more precise colors on the screen.
- 18bit+  
 Improve the LED display grayscale by 4 times to avoid grayscale loss due to low brightness and allow for a smoother image.
- Pixel level brightness and chroma calibration  
 Work with the high-precision calibration system to perform brightness and chroma calibration on each LED to effectively remove brightness differences and chroma differences, enabling high brightness consistency and chroma consistency.
- Quick adjustment of dark or bright lines  
 The dark or bright lines caused by splicing of cabinets or modules can be adjusted to improve

the visual experience. This function is easy to use and the adjustment takes effect immediately.

In NovaLCT V5.2.0 or later, the adjustment can be performed without using or changing the video source.

- **Low latency**  
The latency of video source on the receiving card end can be reduced to 1 frame (only when using modules with driver IC with built-in RAM).
- **3D function**  
Working with the sending card that supports 3D function, the receiving card supports 3D image output.
- **Individual gamma adjustment for RGB**  
Working with NovaLCT (V5.2.0 or later) and the sending card that supports this function, the receiving card supports individual adjustment of red gamma, green gamma and blue gamma, which can effectively control image non-uniformity at low grayscale conditions and white balance offset, allowing for a more realistic image.
- **Image rotation in 90° increments**  
The display image can be set to rotate in multiples of 90° (0°/90°/180°/270°).

### Improvements to Maintainability

- **Smart module (dedicated firmware required)**  
Working with the smart module, the receiving card supports module ID management, storage of calibration coefficients and module parameters, monitoring of module temperature, voltage and flat cable communication status, LED error detection, and recording of the module run time.
- **Automatic module calibration**  
After a new module with flash memory is installed to replace the old one, the calibration coefficients stored in the flash memory can be automatically uploaded to the receiving card when it is powered on.
- **Quick uploading of calibration coefficients**  
The calibration coefficients can be quickly uploaded to the receiving card, improving efficiency greatly.
- **Module Flash management**  
For modules with flash memory, the information stored in the memory can be managed. The calibration coefficients and module ID can be stored and read back.
- **One click to apply calibration coefficients in module Flash**  
For modules with flash memory, when the Ethernet cable is disconnected, users can hold down the self-test button on the cabinet to

upload the calibration coefficients in the flash memory of the module to the receiving card.

- **Mapping function**  
The cabinet can display the receiving card number and Ethernet port information, allowing users to easily obtain the locations and connection topology of receiving cards.
- **Setting of a pre-stored image in receiving card**  
The image displayed during startup, or displayed when the Ethernet cable is disconnected or there is no video signal can be customized.
- **Temperature and voltage monitoring**  
The temperature and voltage of the receiving card can be monitored without using peripherals.
- **Cabinet LCD**  
The LCD module connected to the cabinet can display the temperature, voltage, single run time and total run time of the receiving card.
- **Bit error detection**  
The Ethernet port communication quality of the receiving card can be monitored and the number of erroneous packets can be recorded to help troubleshoot network communication problems. NovaLCT V5.2.0 or later is required.
- **Status detection of dual power supplies**  
When two power supplies are used, their working status can be detected by the receiving card.
- **Firmware program readback**  
The firmware program of the receiving card can be read back and saved to the local computer. NovaLCT V5.2.0 or later is required.
- **Configuration parameter readback**  
The configuration parameters of the receiving card can be read back and saved to the local computer.
- **LVDS transmission (dedicated firmware required)**  
Low-voltage differential signaling (LVDS) transmission is used to reduce the number of data cables from the hub board to module, increase the transmission distance, and improve the signal transmission quality and electromagnetic compatibility (EMC).

### Improvements to Reliability

- **Dual card backup and status monitoring**  
In an application with requirements for high reliability, two receiving cards can be mounted onto a single hub board for backup. When the primary receiving card fails, the backup card can serve immediately to ensure uninterrupted operation of the display.  
The working status of the primary and backup receiving cards can be monitored in NovaLCT V5.2.0 or later.

- **Loop backup**  
The receiving cards and the sending card form a loop via the primary and backup line connections. When a fault occurs at a location of the lines, the screen can still display the image normally.
- **Dual backup of configuration parameters**  
The receiving card configuration parameters are stored in the application area and factory area of the receiving card at the same time. Users usually use the configuration parameters in the application area. If necessary, users can restore the configuration parameters in the factory area to the application area.
- **Dual program backup**  
Two copies of firmware program are stored in the receiving card at the factory to avoid the problem that the receiving card may get stuck due to program update exception.

## Appearance

Top



Power Running Indicator  
Indicator Indicator

Bottom

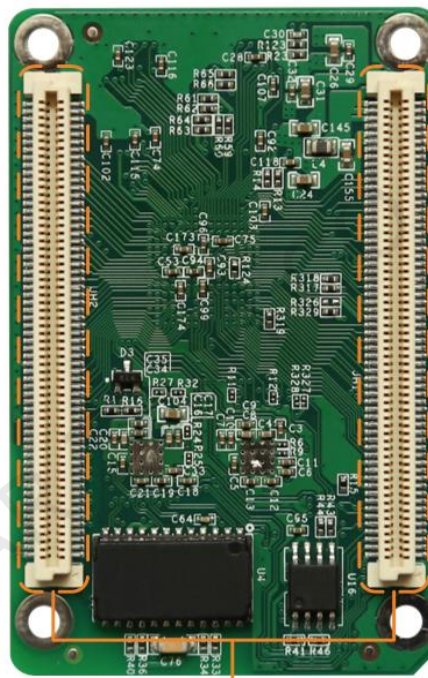

High-Density  
Connectors

All product pictures shown in this document are for illustration purpose only. Actual product may vary.

## Indicators

Indicator	Color	Status	Description
Running indicator	Green	Flashing once every 1s	The receiving card is functioning normally. Ethernet cable connection is normal, and video source input is available.
		Flashing once every 3s	Ethernet cable connection is abnormal.
		Flashing 3 times every 0.5s	Ethernet cable connection is normal, but no video source input is available.
		Flashing once every 0.2s	The receiving card failed to load the program in the application area and is now using the backup program.
		Flashing 8 times every 0.5s	A redundancy switchover occurred on the Ethernet port and the loop backup has taken effect.
Power indicator	Red	Always on	The power input is normal.

## Dimensions

The board thickness is not greater than 2.0 mm, and the total thickness (board thickness + thickness of components on the top and bottom sides) is not greater than 8.5 mm. Ground connection (GND) is enabled for mounting holes.

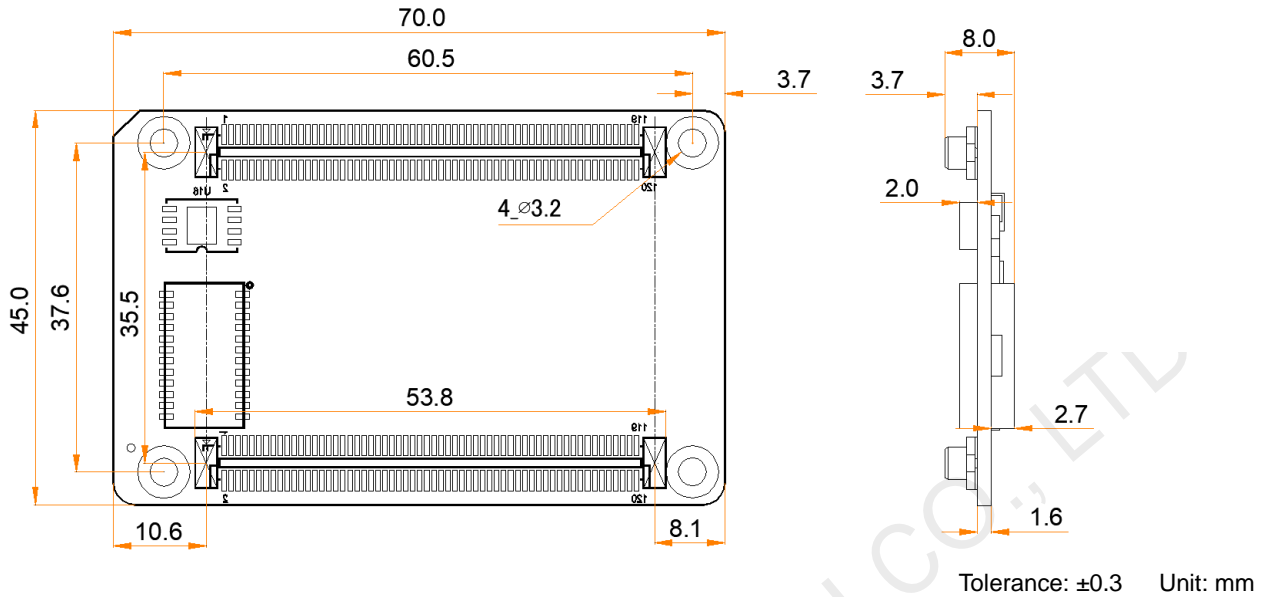

### Note

The distance between outer surfaces of the A5s Plus (E) and hub boards after their high-density connectors fit together is 5.0 mm. A 5-mm copper pillar is recommended.



JH1					
/	G21	41	42	R21	/
/	R22	43	44	B21	/
/	B22	45	46	G22	/
/	G23	47	48	R23	/
/	R24	49	50	B23	/
/	B24	51	52	G24	/
	GND	53	54	GND	
/	G25	55	56	R25	/
/	R26	57	58	B25	/
/	B26	59	60	G26	/
/	G27	61	62	R27	/
/	R28	63	64	B27	/
/	B28	65	66	G28	/
	GND	67	68	GND	
/	G29	69	70	R29	/
/	R30	71	72	B29	/
/	B30	73	74	G30	/
/	G31	75	76	R31	/
/	R32	77	78	B31	/
/	B32	79	80	G32	/
	GND	81	82	GND	
/	RFU4	83	84	RFU3	/
/	RFU6	85	86	RFU5	/
/	RFU8	87	88	RFU7	/
/	RFU10	89	90	RFU9	/
/	RFU12	91	92	RFU11	/
/	RFU14	93	94	RFU13	/
	GND	95	96	GND	
/	RFU16	97	98	RFU15	/
/	RFU18	99	100	RFU17	/
	NC	101	102	NC	
	NC	103	104	NC	
	NC	105	106	NC	
	NC	107	108	NC	
	GND	109	110	GND	
	GND	111	112	GND	
	NC	113	114	NC	
	VCC	115	116	VCC	
	VCC	117	118	VCC	
	VCC	119	120	VCC	

JH2					
Chassis ground	Eth_Sheild	1	2	Eth_Sheild	Chassis ground
Chassis ground	Eth_Sheild	3	4	Eth_Sheild	Chassis ground
	NC	5	6	NC	
	NC	7	8	NC	
Gigabit Ethernet port	Port1_T0+	9	10	Port2_T0+	Gigabit Ethernet port
	Port1_T0-	11	12	Port2_T0-	
	NC	13	14	NC	
	Port1_T1+	15	16	Port2_T1+	
	Port1_T1-	17	18	Port2_T1-	
	NC	19	20	NC	
	Port1_T2+	21	22	Port2_T2+	

JH2					
	Port1_T2-	23	24	Port2_T2-	
	NC	25	26	NC	
	Port1_T3+	27	28	Port2_T3+	
	Port1_T3-	29	30	Port2_T3-	
	NC	31	32	NC	
	NC	33	34	NC	
Test button	TEST_INPUT_KEY	35	36	STA_LED-	Running indicator (active low)
	GND	37	38	GND	
Line decoding signal	A	39	40	DCLK	Shift clock output 1
Line decoding signal	B	41	42	DCLK_2	Shift clock output 2
Line decoding signal	C	43	44	LAT	Latch signal output
Line decoding signal	D	45	46	CTRL	Afterglow control signal
Line decoding signal	E	47	48	OE_RED	Display enable
Display enable	OE_BLUE	49	50	OE_GREEN	Display enable
	GND	51	52	GND	
/	G1	53	54	R1	/
/	R2	55	56	B1	/
/	B2	57	58	G2	/
/	G3	59	60	R3	/
/	R4	61	62	B3	/
/	B4	63	64	G4	/
	GND	65	66	GND	
/	G5	67	68	R5	/
/	R6	69	70	B5	/
/	B6	71	72	G6	/
/	G7	73	74	R7	/
/	R8	75	76	B7	/
/	B8	77	78	G8	/
	GND	79	80	GND	
/	G9	81	82	R9	/
/	R10	83	84	B9	/
/	B10	85	86	G10	/
/	G11	87	88	R11	/
/	R12	89	90	B11	/
/	B12	91	92	G12	/
	GND	93	94	GND	
/	G13	95	96	R13	/
/	R14	97	98	B13	/
/	B14	99	100	G14	/
/	G15	101	102	R15	/
/	R16	103	104	B15	/
/	B16	105	106	G16	/
	GND	107	108	GND	
	NC	109	110	NC	
	NC	111	112	NC	
	NC	113	114	NC	
	NC	115	116	NC	
	GND	117	118	GND	
	GND	119	120	GND	

### 64 Groups of Serial Data

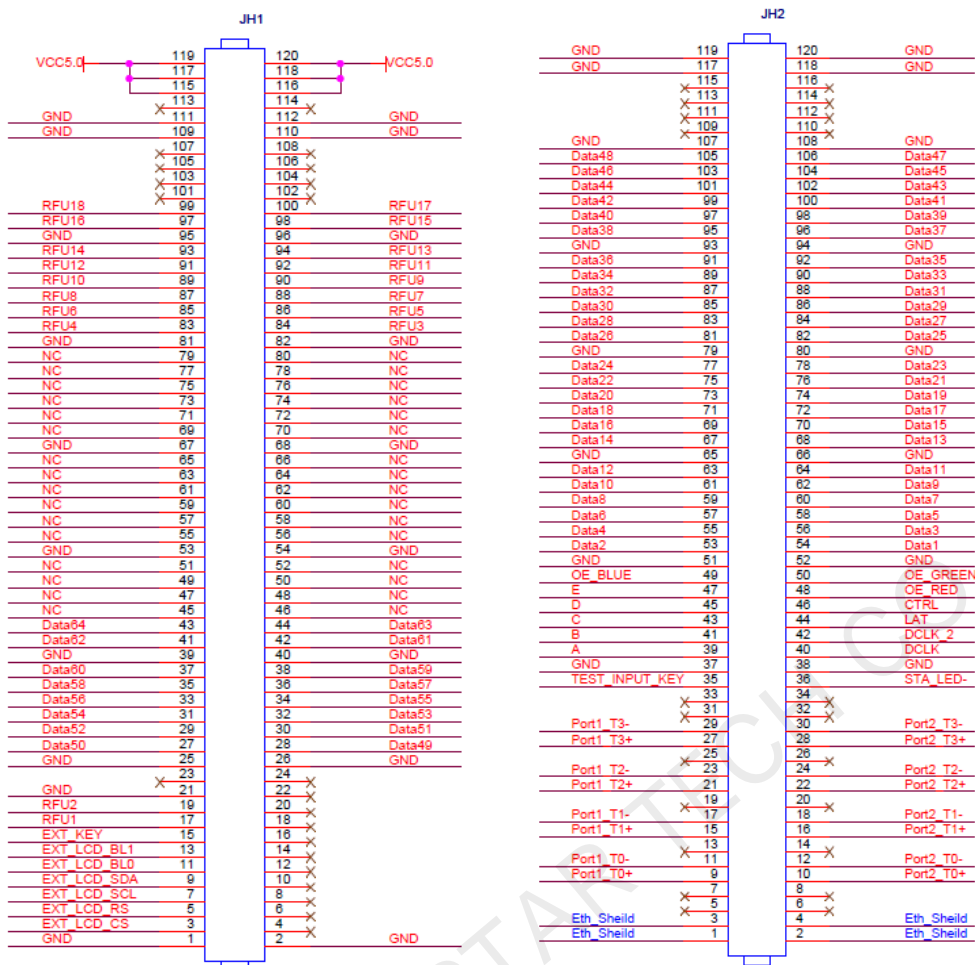

JH1					
	GND	1	2	GND	
LCD CS signal	EXT_LCD_CS	3	4	NC	
LCD RS signal	EXT_LCD_RS	5	6	NC	
LCD clock signal	EXT_LCD_SCL	7	8	NC	
LCD data signal	EXT_LCD_SDA	9	10	NC	
LCD backlight signal 1	EXT_LCD_BL0	11	12	NC	
LCD backlight signal 2	EXT_LCD_BL1	13	14	NC	
LCD control button	EXT_KEY	15	16	NC	
/	RFU1	17	18	NC	
/	RFU2	19	20	NC	
	GND	21	22	NC	
	NC	23	24	NC	
	GND	25	26	GND	
/	Data50	27	28	Data49	/
/	Data52	29	30	Data51	/
/	Data54	31	32	Data53	/
/	Data56	33	34	Data55	/
/	Data58	35	36	Data57	/
/	Data60	37	38	Data59	/
	GND	39	40	GND	
/	Data62	41	42	Data61	/
/	Data64	43	44	Data63	/
	NC	45	46	NC	

JH1					
	NC	47	48	NC	
	NC	49	50	NC	
	NC	51	52	NC	
	GND	53	54	GND	
	NC	55	56	NC	
	NC	57	58	NC	
	NC	59	60	NC	
	NC	61	62	NC	
	NC	63	64	NC	
	NC	65	66	NC	
	GND	67	68	GND	
	NC	69	70	NC	
	NC	71	72	NC	
	NC	73	74	NC	
	NC	75	76	NC	
	NC	77	78	NC	
	NC	79	80	NC	
	GND	81	82	GND	
/	RFU4	83	84	RFU3	/
/	RFU6	85	86	RFU5	/
/	RFU8	87	88	RFU7	/
/	RFU10	89	90	RFU9	/
/	RFU12	91	92	RFU11	/
/	RFU14	93	94	RFU13	/
	GND	95	96	GND	
/	RFU16	97	98	RFU15	/
/	RFU18	99	100	RFU17	/
	NC	101	102	NC	
	NC	103	104	NC	
	NC	105	106	NC	
	NC	107	108	NC	
	GND	109	110	GND	
	GND	111	112	GND	
	NC	113	114	NC	
	VCC	115	116	VCC	
	VCC	117	118	VCC	
	VCC	119	120	VCC	

JH2					
Chassis ground	Eth_Sheild	1	2	Eth_Sheild	Chassis ground
Chassis ground	Eth_Sheild	3	4	Eth_Sheild	Chassis ground
	NC	5	6	NC	
	NC	7	8	NC	
Gigabit Ethernet port	Port1_T0+	9	10	Port2_T0+	Gigabit Ethernet port
	Port1_T0-	11	12	Port2_T0-	
	NC	13	14	NC	
	Port1_T1+	15	16	Port2_T1+	
	Port1_T1-	17	18	Port2_T1-	
	NC	19	20	NC	
	Port1_T2+	21	22	Port2_T2+	
	Port1_T2-	23	24	Port2_T2-	
	NC	25	26	NC	
	Port1_T3+	27	28	Port2_T3+	

JH2					
	Port1_T3-	29	30	Port2_T3-	
	NC	31	32	NC	
	NC	33	34	NC	
Test button	TEST_INPUT_KEY	35	36	STA_LED-	Running indicator (active low)
	GND	37	38	GND	
Line decoding signal	A	39	40	DCLK	Shift clock output 1
Line decoding signal	B	41	42	DCLK_2	Shift clock output 2
Line decoding signal	C	43	44	LAT	Latch signal output
Line decoding signal	D	45	46	CTRL	Afterglow control signal
Line decoding signal	E	47	48	OE_RED	Display enable
Display enable	OE_BLUE	49	50	OE_GREEN	Display enable
	GND	51	52	GND	
/	Data2	53	54	Data1	/
/	Data4	55	56	Data3	/
/	Data6	57	58	Data5	/
/	Data8	59	60	Data7	/
/	Data10	61	62	Data9	/
/	Data12	63	64	Data11	/
	GND	65	66	GND	
/	Data14	67	68	Data13	/
/	Data16	69	70	Data15	/
/	Data18	71	72	Data17	/
/	Data20	73	74	Data19	/
/	Data22	75	76	Data21	/
/	Data24	77	78	Data23	/
	GND	79	80	GND	
/	Data26	81	82	Data25	/
/	Data28	83	84	Data27	/
/	Data30	85	86	Data29	/
/	Data32	87	88	Data31	/
/	Data34	89	90	Data33	/
/	Data36	91	92	Data35	/
	GND	93	94	GND	
/	Data38	95	96	Data37	/
/	Data40	97	98	Data39	/
/	Data42	99	100	Data41	/
/	Data44	101	102	Data43	/
/	Data46	103	104	Data45	/
/	Data48	105	106	Data47	/
	GND	107	108	GND	
	NC	109	110	NC	
	NC	111	112	NC	
	NC	113	114	NC	
	NC	115	116	NC	
	GND	117	118	GND	
	GND	119	120	GND	

#### Note

The recommended VCC power input is 5.0 V.

OE\_RED, OE\_GREEN and OE\_BLUE are display enable signals. When RGB are not controlled separately, use OE\_RED. When the PWM chip is used, they are used as GCLK signals.

In the mode of 128 groups of serial data, Data65–Data128 are multiplexed into Data1–Data64.

## Reference Design for Extended Functions

Pins for Extended Functions			
Pin	Recommended Module Flash Pin	Recommended Smart Module Pin	Description
RFU4	HUB_SPI_CLK	Reserved	Clock signal of serial pin
RFU6	HUB_SPI_CS	Reserved	CS signal of serial pin
RFU8	HUB_SPI_MOSI	/	Module Flash data storage input
	/	HUB_UART_TX	Smart module TX signal
RFU10	HUB_SPI_MISO	/	Module Flash data storage output
	/	HUB_UART_RX	Smart module RX signal
RFU3	HUB_CODE0		Module Flash BUS control pin
RFU5	HUB_CODE1		
RFU7	HUB_CODE2		
RFU9	HUB_CODE3		
RFU18	HUB_CODE4		
RFU11	HUB_H164_CSD		74HC164 data signal
RFU13	HUB_H164_CLK		
RFU14	POWER_STA1		Dual power supply detection signal
RFU16	POWER_STA2		
RFU15	MS_DATA		Dual card backup connection signal
RFU17	MS_ID		Dual card backup identifier signal

### Note

The RFU8 and RFU10 are signal multiplex extension pins. Only one pin from either the Recommended Smart Module Pin or the Recommended Module Flash Pin can be selected at the same time.

## Specifications

Maximum Loading Capacity	512×384 pixels	
Electrical Parameters	Input voltage	DC 3.3 V to 5.5 V
	Rated current	0.6 A
	Rated power consumption	3.0 W
Operating Environment	Temperature	-20°C to +70°C
	Humidity	10% RH to 90% RH, non-condensing
Storage Environment	Temperature	-25°C to +125°C
	Humidity	0% RH to 95% RH, non-condensing
Physical Specifications	Dimensions	70.0 mm × 45.0 mm × 8.0 mm
	Net weight	16.2 g Note: It is the weight of a single receiving card only.
	Gross weight	1.2 kg Note: It is the total weight of the products, printed materials and packing materials packed according to the packing specifications.
Packing	Packing specifications	Each receiving card is packaged in a blister pack. Each

Information		packing box contains 80 receiving cards.
	Packing box dimensions	378.0 mm × 190.0 mm × 120.0 mm

The amount of current and power consumption may vary depending on many factors such as product settings, usage, and environment.

XI'AN NOVASTAR TECH CO., LTD

**Copyright © 2021 Xi'an NovaStar Tech Co., Ltd. All Rights Reserved.**

No part of this document may be copied, reproduced, extracted or transmitted in any form or by any means without the prior written consent of Xi'an NovaStar Tech Co., Ltd.

#### **Trademark**

**NOVA STAR** is a trademark of Xi'an NovaStar Tech Co., Ltd.

#### **Statement**

Thank you for choosing NovaStar's product. This document is intended to help you understand and use the product. For accuracy and reliability, NovaStar may make improvements and/or changes to this document at any time and without notice. If you experience any problems in use or have any suggestions, please contact us via the contact information given in this document. We will do our best to solve any issues, as well as evaluate and implement any suggestions.

[Official website](http://www.novastar.tech)  
www.novastar.tech

[Technical support](mailto:support@novastar.tech)  
support@novastar.tech