

BOE MLED COB

BYH Ultra Series

Introduction

1. Quick View for Selling Points

BYH Ultra Series

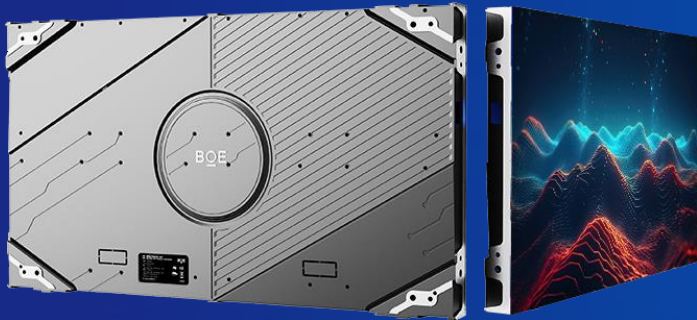

□ Extreme image quality

- No modular display problems, **large viewing angle without color seams**;
- High brightness **Typ.1500nit Max.2000nit**, static contrast ratio **≥20000:1**, DCI-P3 **Typ.99%**
- Splicing seam&segment difference **< 50um**, module size of **14.5inch for P0.9&1.2**
- High grayscale **16bit** and Ultra-high refresh rate **7680Hz**

□ Green saving

- Low power consumption of **180W/m²** @600nit, low panel temperature **≤37°C**

□ Fast installation and maintenance

- Support **mounting bracket** design, doubling installation efficiency
- Module surfaces are **dirt-resistant** and **easy wiping**

□ Stable quality

- **1000h** reliability test passed, Support **Dual-link (optional)**

2. Good Ink Uniformity

- Good ink uniformity small deviation $\Delta L < 0.23$
- Ink uniformity belongs to **blue&black**, less noticeable for color differences

Ink uniformity test result

ITEM	MLED	Other
ΔL	0.23	0.54
a	-0.7	0.68
b	-2.0	1.51

BOE

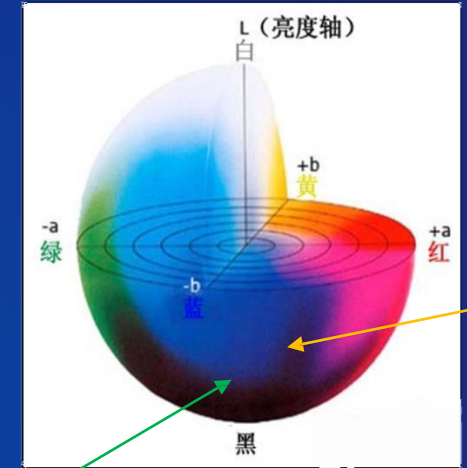

other

BOE

black&red

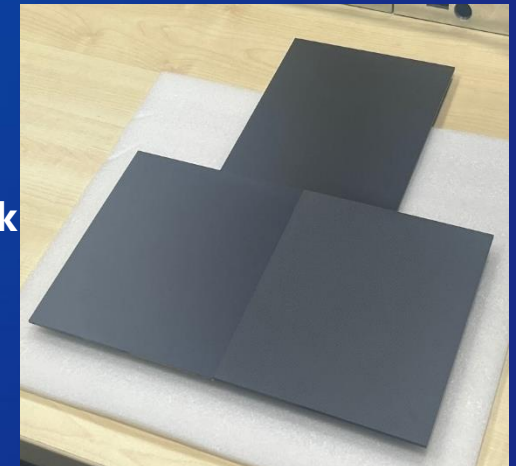

blue&black



black&white

The human eye's ability to distinguish between detailed colors

Color	B&W	B&G	B&R	B&B	G&R	R&Blue	G&blue
Distinguishing Power	100%	94%	90%	26%	40%	23%	19%

3. Low Glossiness

- 85° glossiness < 10, non-reflective, anti-glare;
- Self-developed film microstructure design brings **matte** surface appearance.

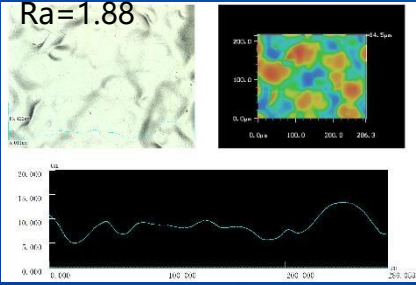
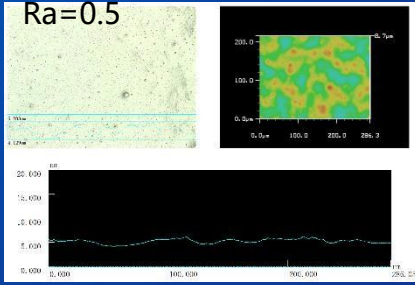
ITEM	MLED	Other
85°glossiness	9.5	24.6
Surface		
Microstructure		

4. High Brightness&Color Gamut

- Color gamut: DCI-P3 Typ. 99%
- Brightness: Typ.1500nit Max. 2000nit
- Contrast ratio (ACR): 20000:1 at 10lux

BOE



Common COB product

High Brightness&gamut
COB product

5. Increase Flatness

- Large panel **splicing seam&segment difference $\leq 50 \mu\text{m}$** , High consistency of dark state visual effect, no splicing bump feeling



Before adjustment

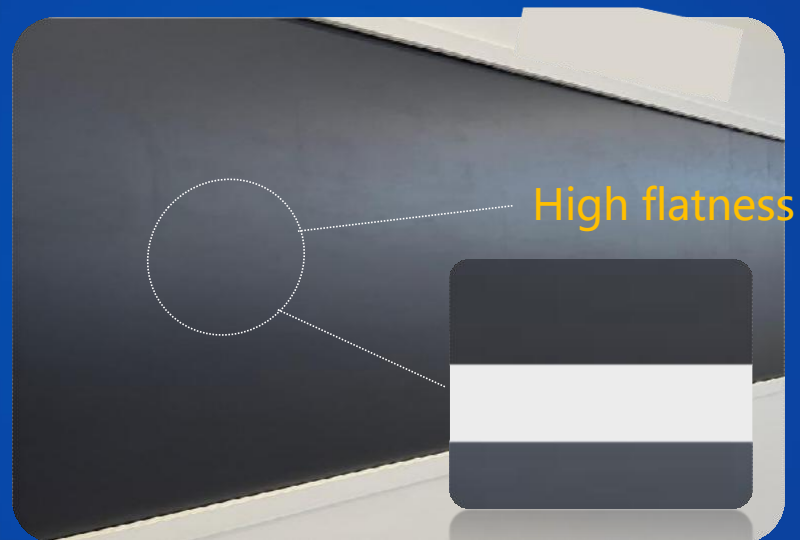

After adjustment

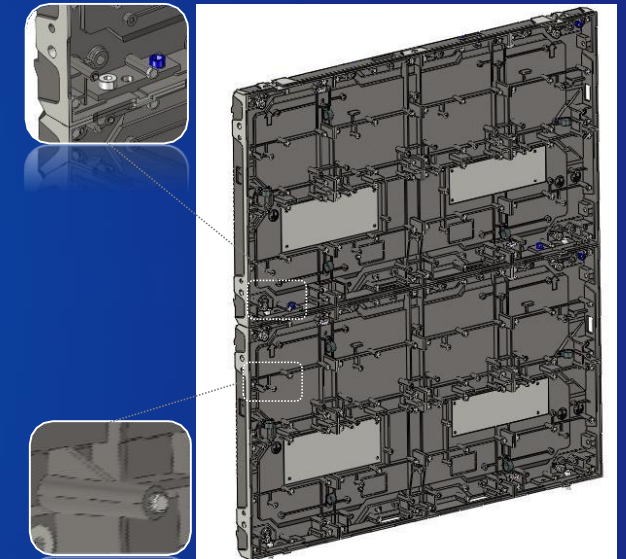

XYZ 6-way adjustable

6. Ultra-low power consumption

- Ultra-low power consumption 180W/m²@600nit, realization of ≤37°C cold screen below human body temperature

Brightness (nit)	Power (W/m ²)	Power (W/nit/m ²)	Heat (BTU/nit/m ²)	Temperature (°C)	temperature rise(°C)
600	180	0.3	1.0	35	12
1200	286	0.24	0.8	43	20
1500	343	0.23	0.78	46	23

* Ta=23°C

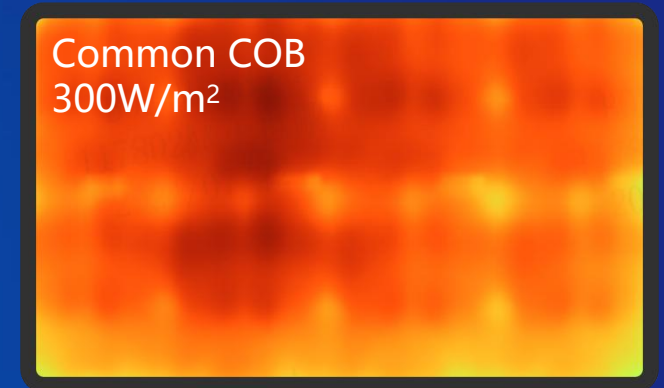

Power consumption ↓46%

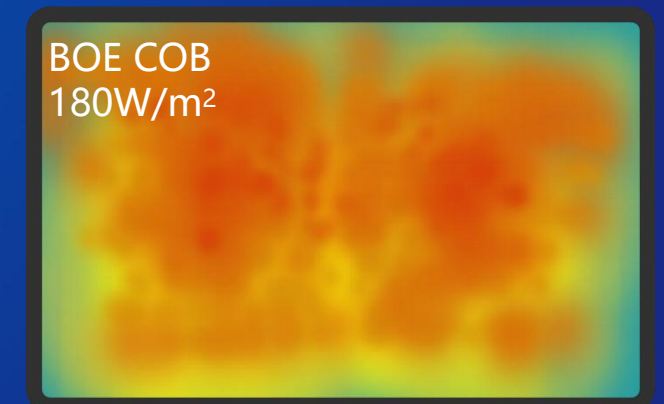

* @600nit

7. Green Saving

- Temperature in front of panel $\leq 37^{\circ}\text{C}$, lower than body temperature, electricity savings of **5.2 kWh/day**, reduce carbon emissions of **3kg/day**@4K display



8. Larger Module Size

- Module size 8.9inch → **14.5inch**, **25%** reduction in the number of seams, also reduce the installation cost



8.9inch 150*168.75mm

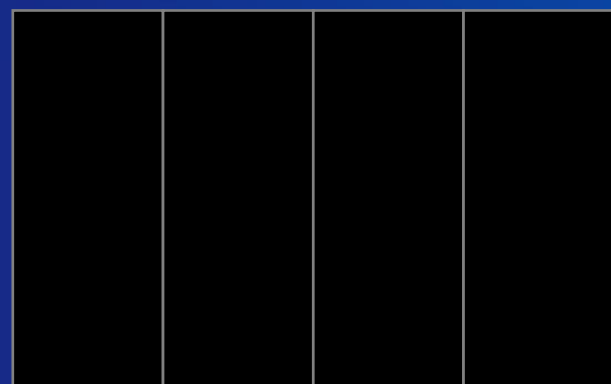

14.5inch 150*337.5 for P0.9-1.2

288EA

144EA

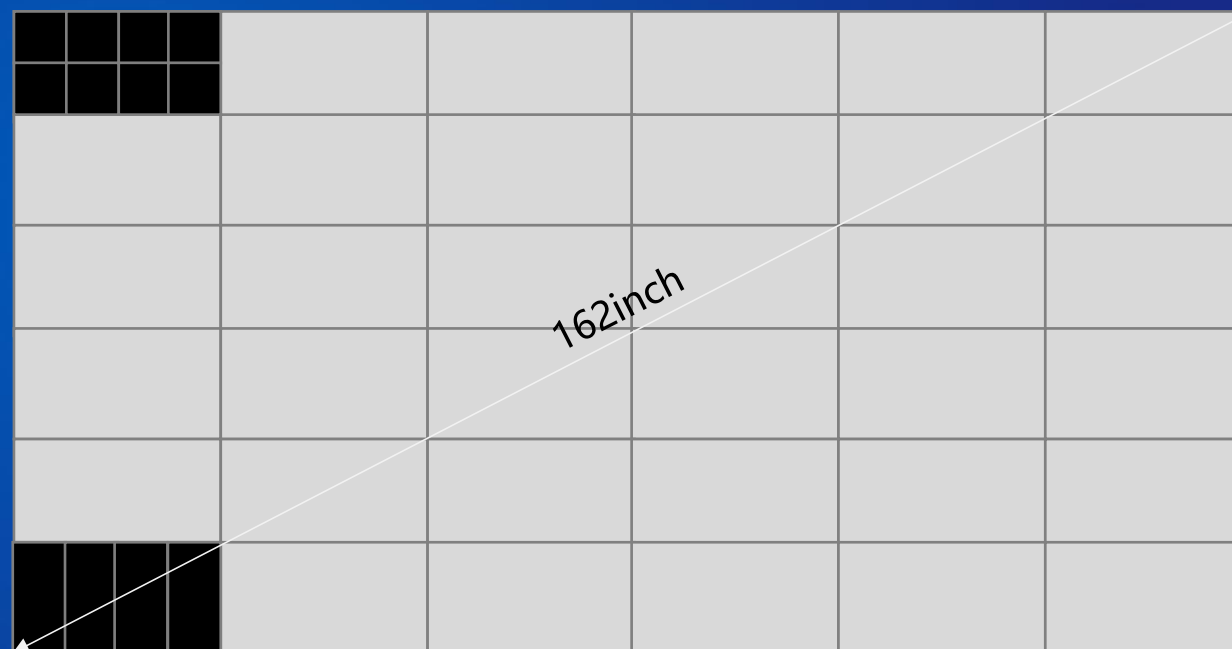

9. Installation Efficiency

□ support mounting bar design, increase installation efficiency by 50%



Stacking Installation

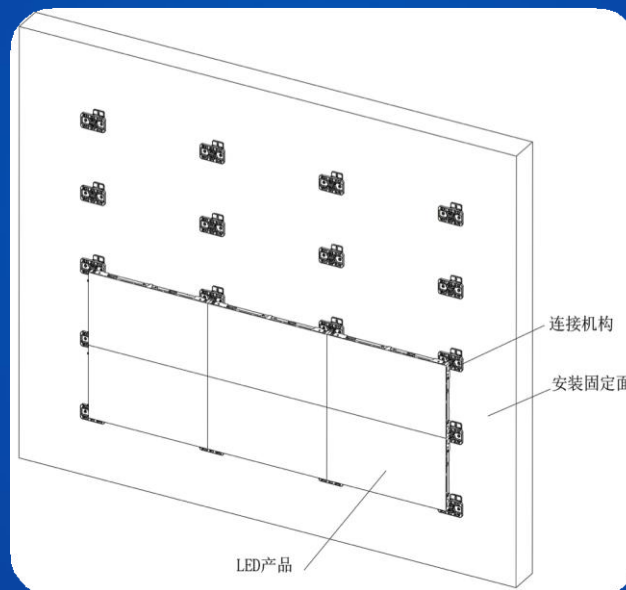

Fast installation without steel frame

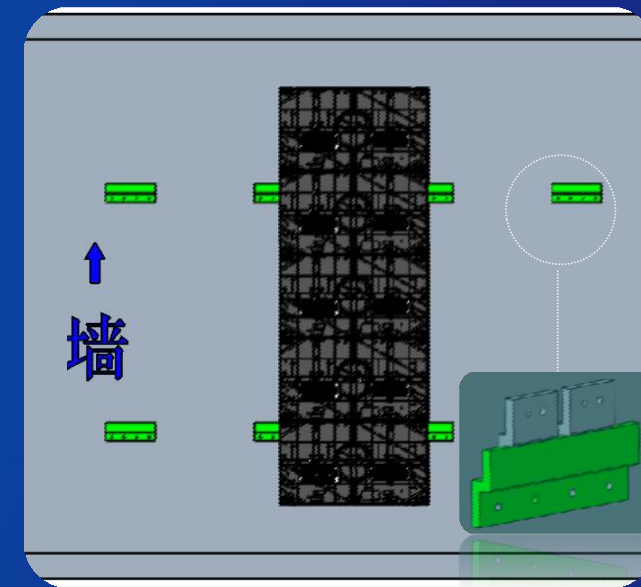

Mounting bar

10. Easy Maintenance

□ Module surfaces are dirt-resistant and easy wiping

3D Figure	Haze		Roughness/Ra		Wiping Difficulty	Fingerprint residue
	Low	<30	Extra Low	<0.5		
	Low	<30	Extra Low	<0.5	Easy	Bad
	Medium	~60	Medium	<2	Easy	Good
	High	>80	High	>2	Hard	Good

MLED COB 60% Haze, Ra≈1.5um



Others



MLED

11. Quality Assurance

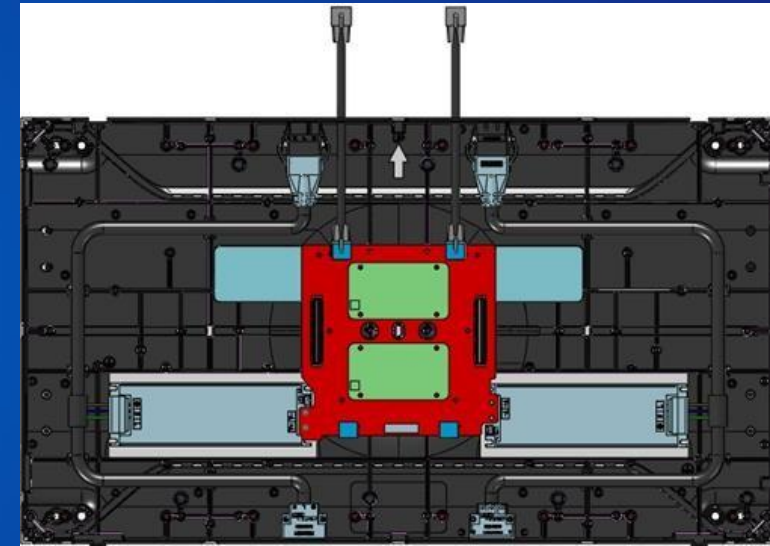
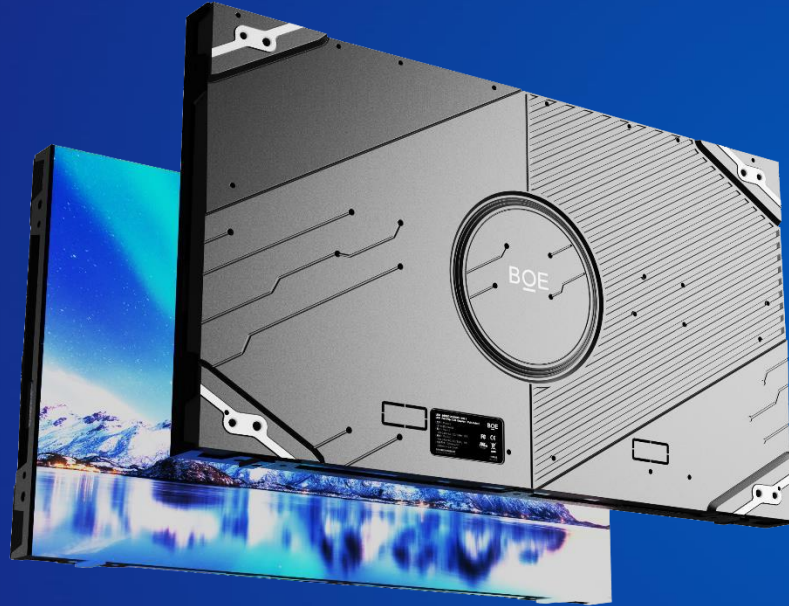

- 1000h reliability test passed

- Dual backup for PSU and receiving card

12. Regulation



13. Application Scenarios



Business Lobby



Retail

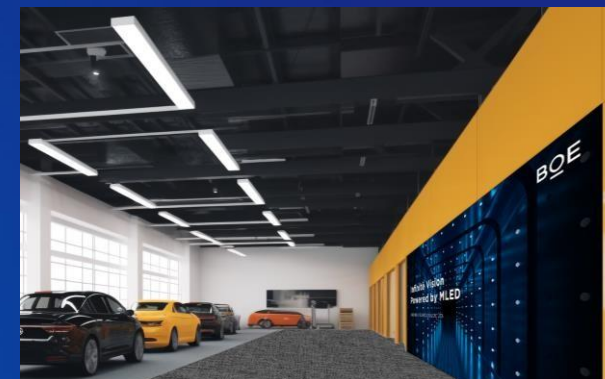

Car Dealership



Conference Room



Showroom



Data Center



Auditorium



Flagship Store